

The logo features the word "DAVEY" in a bold, white, sans-serif font, centered within a black rounded rectangular background. Below the text is a white wavy line that tapers at both ends, resembling a stylized wave or a pump's discharge path.

DAVEY

Installation and Operating Instructions

Davey Everyday Series E1P - E3P (XJ50P/XJ70P/XJ90P) Pressure Pumps & XJ50/XJ70/XJ90 Electric Pumps



NOTE: Prior to installation remove the inlet and outlet pipe transport plugs & associated seals from the suction and/or discharge ports.



Please pass these instructions on to the operator of this equipment.

Prior to using this pump you must ensure that:

- The pump is installed in a safe and dry environment
- The pump enclosure has adequate drainage in the event of leakage
- Any transport plugs are removed
- The pipe-work is correctly sealed and supported
- The pump is primed correctly
- The power supply is correctly connected
- All steps have been taken for safe operation

Appropriate details for all of these items are contained in the following Installation and Operating Instructions. Read these in their entirety before switching on this pump. If you are uncertain as to any of these Installation and Operating Instructions please contact your Davey dealer or the appropriate Davey office as listed on the back of this document.

Congratulations on your purchase of a high quality, Australian built Davey pressure pump. All components have been designed and manufactured to give trouble free, reliable operation.

Before installing your new pump, please read all instructions carefully as failures caused by incorrect installation or operation are not covered by the guarantee. Your Dynajet® XJ pump is designed to handle clean water. It should not be used for any other purpose without specific referral to Davey. The use of the pump to handle flammable, corrosive and other materials of a hazardous nature is specifically excluded.

XJ50P / E2P / E3P

1. Pressure tank
(supplied separately)
2. Pressure switch
3. Delivery outlet (1" F)
4. Suction inlet
(X50P = 1" F)
(E2P & E3P = 1 1/4" F)
5. Pump body
6. Motor

XJ50 / XJ70 / XJ90

Are the same as above
less items 1 & 2.

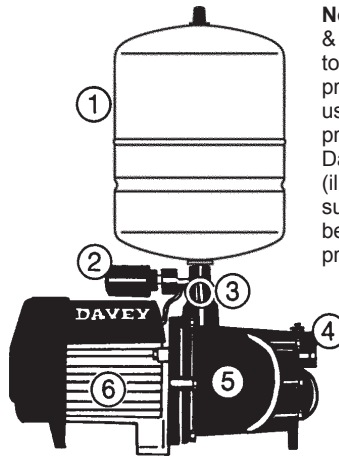

Note: Your XJ Ultra, E2P & E3P pump is designed to operate as an automatic pressure system when used in conjunction with a pressure tank such as a Davey "Supercell 18" tank (illustrated). The tank, supplied separately, needs to be fitted to the delivery outlet prior to operating.

Assembly

4 Attach pressure switch (2) to the delivery outlet tee (3) by hand tightening the pressure switch union nut (ensure sealing oring is in place). Screw pressure tank (1) onto delivery outlet.



Do not use this pump to pump flammable fluids, such as petrol or diesel fuels.

Choosing a Site

Choose a site with a firm base and as close to the water source as possible with correct power supply. Make sure your pressure system is always connected to an adequate, reliable source of clean water.

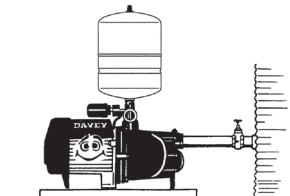

Housing your Davey Pressure System

To protect your pressure system from the weather, make sure the pump house is both water proof, frost free and has adequate ventilation. The pump should be horizontally mounted on a firm base allowing for drainage, to avoid damage to flooring etc., that over time may occur from leaking pipe joints or pump seals. Do not mount the pump vertically.



WARNING: Some insects, such as small ants, find electrical devices attractive for various reasons. If your pump enclosure is susceptible to insect infestation you should implement a suitable pest control plan.



Power Connection

Connect lead to power supply designated on pump label, do not use long extension leads as they cause substantial voltage drop, poor pump performance and may cause motor overload.

Pipe Connections

For best performance use P.V.C. or polythene pipes at least the same diameter as the pump's inlet and delivery outlet openings. Larger diameter pipe may be used to minimise resistance to flow when pumping longer distances.

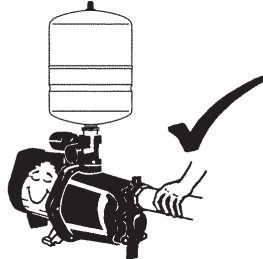
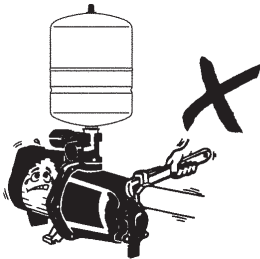

Do not use pipe thread sealing compounds on any part of this pump. ONLY use Teflon sealing tape.

Use unions at pipe connections to enable easy removal and servicing. Use sufficient tape to ensure airtight seal and hand tighten only. To prevent strain on pump threads always support heavy inlet and outlet pipes. If there is a likelihood the water supply may contain solid particles such as pieces of plant or vegetable matter, a suction strainer should be installed before the pump to avoid blocking of the pump. Lay suction pipe at a constant gradient to avoid air pockets which may reduce pump efficiency.



NOTE: Suction leaks are the largest cause of poor pump performance and are difficult to detect. Ensure all connections are completely sealed using thread tape only.

Where to use Check Valves and Foot Valves

Installations with a suction lift over 1m require a good quality foot valve to avoid loss of prime. In this case, the poppet valve inside the pump should be removed. Installations with flooded suction require a gate valve so water supply can be turned off for pump removal and servicing.

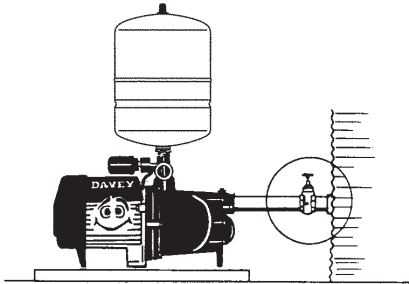

Use gate valve for flooded suction

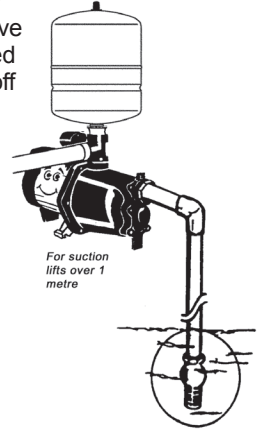

Abrasive Materials
The pumping of abrasive materials will cause damage to the pressure system which will then not be covered by the guarantee.



IMPORTANT
For Automatic Pressure Pumps Installed with a Mains Pressure Hot Water System.

A good quality non-return valve must be installed in the pressure pump outlet pipework before the hot water service. Failure to install this non-return valve may result in pump damage. Such damage is not covered by guarantee.

Connection of Mains Scheme or Town Water Supply to either Suction or Discharge of Pumps & Pressure Systems

Most Water Supply Authorities have strict regulations regarding direct connection of pumps to mains water supplies. In most cases an isolating tank is required between mains supply and pump. Davey also recommend this method. Directly applied mains pressure can exceed pump operating pressure and damage pump.

Davey Water Products Pty Ltd can not accept responsibility for loss or damage resulting from incorrect or unauthorised installations.

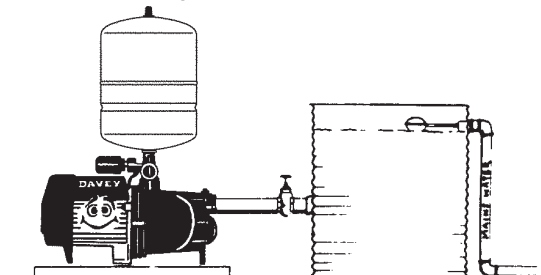
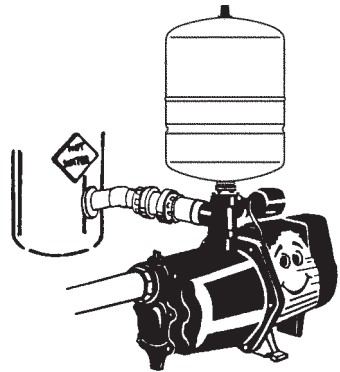

Connection to your Water Source

BELOW GROUND WATER SOURCES

Whenever the installation position of the pump is higher than 1m (3.3ft) above the lowest water level, a foot valve must be used on the end of the suction pipe as illustrated in (C) below. Ensure that the foot valve is at least 1/2 metre below minimum water level.

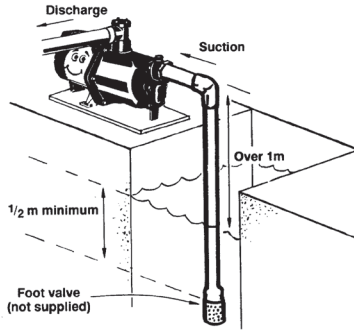

(C) SUCTION LIFT

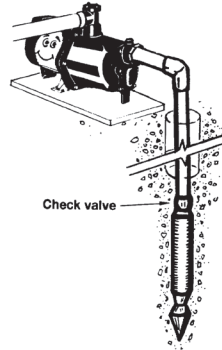

(D) SPEAR POINT

SPEAR POINT INSTALLATIONS

When a Dynajet® is installed on a spear or well point, a check valve must be fitted immediately on top of the spear point itself, as shown in (D) above. **DO NOT INSTALL THE CHECK VALVE AT THE PUMP OR AT THE TOP OF THE WELL. DO NOT RUN THE PUMP WITHOUT WATER.**

NOTE: Be certain to select the spear point to suit the well conditions and regulate the flow rate from the pump accordingly.

SPEAR SIZE POINT	MESH	APPROX. MAX. CAPACITY OF SPEAR
1 1/4" (32mm)	60	15 - 23 l/min or 200 - 300 gal/hr
1 1/2" (38mm)	60	23 - 38 l/min or 300 - 500 gal/hr
2" (50mm)	60	38 - 75 l/min or 500 - 1000 gal/hr



Spear point flow capacities vary considerably. Check with the supplier to ensure the pump and spear point are correctly matched.

Priming and Operation

1. Fill pump and suction line (on flooded suction, simply open gate valve to pump). When full, fit Supercell Pressure Tank or Priming Plug as applicable.
2. Ensure outlet nearest to pump is open.

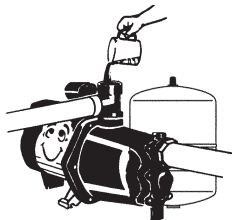

3. Ensure all valves in suction line are open and switch on.

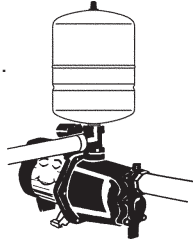

4. Prime should establish almost immediately and a strong flow of water should be evident from the outlet. Allow water to flow for 10-20 seconds to expel air then close outlet.

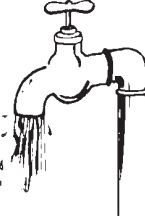

5. Automatic Pressure Pumps will shut down automatically within several seconds. Manual systems must be switched off at the power point.

6. If no flow is evident from tap, switch off at power point and repeat from step 1 ensuring there is an adequate supply of water available to the pump.



Never operate your Davey Dynajet® pump for more than a few seconds without discharge flow.

Maintenance

The only regular attention your new pressure system requires is to check the pressure tank's air charge every 6 months. This can be checked at the air valve with a tyre gauge. Do not charge tank to a higher pressure than 168kPa for E1P (XP50P) or 196kPa for E2P & E3P (XJ70P & XJ90P).

To check air pressure in tank:

1. Switch off pump.
2. Open outlet nearest to pump to release water pressure.
3. Remove air valve cap from top of Supercell tank and charge tank to 168kPa for E1P (XP50P) or 196kPa for E2P & E3P (XJ70P & XJ90P) using air pump and check with tyre gauge.
4. Switch on.
5. Close outlet.

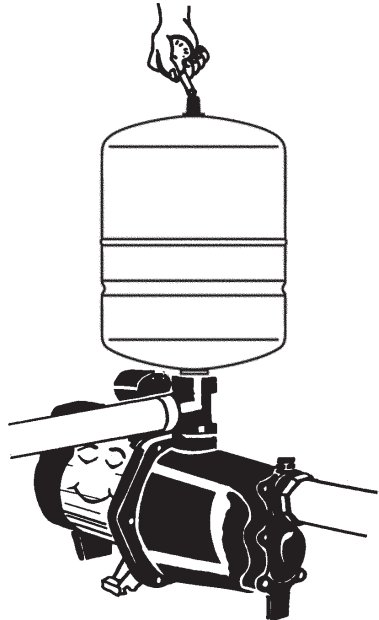

Trouble Shooting Check List

- a) **MOTOR RUNS WHEN SWITCHED ON BUT DOES NOT PUMP.**
1. Suction line and pump body not filled with water.
 2. Air leaks in suction lines or suction pipe not under water.
 3. Air trapped in suction lines (also possible with flooded suction due to uneven rise in piping; eliminate humps and hollows).
 4. No water at source or water level too low.
 5. Valve on suction lines closed.
- b) **PUMP SWITCHES ON AND OFF FREQUENTLY (CYCLING) - Pressure Pumps Only**
1. Check that tank air pressure is correct - see above.
 2. Leaking taps, float valves etc. check plumbing.
 3. Leaking check valve/foot valve.
- c) **MOTOR DOESN'T START WHEN SWITCHED ON.**
1. Power not connected.
 2. Supply voltage too low.
 3. "Over temperature" cut-out tripped.*
 4. Motor not free to turn eg. a jammed impeller.
 5. Internal motor fault.



***NOTE: For protection, the Davey pump motor is fitted with an automatic "over temperature" cut-out. Constant tripping of this overload device indicates a problem eg. low voltage at pump, excessive temperature (above 45°C) in pump enclosure.**



WARNING: When servicing or attending pump, always ensure power is switched off and lead unplugged. Electrical connections should be serviced only by qualified persons.



Care should also be taken when servicing or disassembling pump to avoid possible injury from hot pressurised water. Unplug pump, relieve pressure by opening a tap on the discharge side of the pump and allow any hot water in the pump to cool before attempting to dismantle.



During servicing, use only approved, non-petrochemical based oring and gasket lubrication. If unsure, consult your Davey Dealer for advice.



WARNING: Do not use hydrocarbon based or hydrocarbon propelled sprays around the electrical components of this pump.



In accordance with AS/NZS 60335.2.41 we are obliged to inform you that this pump is not to be used by children or infirm persons and must not be used as a toy by children.

Davey Repair or Replacement Guarantee

In the unlikely event in Australia or New Zealand that this Davey product develops any malfunction within two years of the date of original purchase due to faulty materials or manufacture, Davey will at our option repair or replace it for you free of charge, subject to the conditions below.

Should you experience any difficulties with your Davey product, we suggest in the first instance that you contact the Davey Dealer from which you purchased the Davey product. Alternatively you can phone our Customer Service line on 1300 367 866 in Australia, or 0800 654 333 in New Zealand, or send a written letter to Davey at the address listed below. On receipt of your claim, Davey will seek to resolve your difficulties or, if the product is faulty or defective, advise you on how to have your Davey product repaired, obtain a replacement or a refund.

Your Davey Two Year Guarantee naturally does not cover normal wear or tear, replacement of product consumables (i.e. mechanical seals, bearings or capacitors), loss or damage resulting from misuse or negligent handling, improper use for which the product was not designed or advertised, failure to properly follow the provided installation and operating instructions, failure to carry out maintenance, corrosive or abrasive water or other liquid, lightning or high voltage spikes, or unauthorised persons attempting repairs. Where applicable, your Davey product must only be connected to the voltage shown on the nameplate.

Your Davey Two Year Guarantee does not cover freight or any other costs incurred in making a claim. Please retain your receipt as proof of purchase; you **MUST** provide evidence of the date of original purchase when claiming under the Davey Two Year Guarantee.

Davey shall not be liable for any loss of profits or any consequential, indirect or special loss, damage or injury of any kind whatsoever arising directly or indirectly from Davey products. This limitation does not apply to any liability of Davey for failure to comply with a consumer guarantee applicable to your Davey product under the Australian or New Zealand legislation and does not affect any rights or remedies that may be available to you under the Australian or New Zealand Consumer Legislation.

In Australia, you are entitled to a replacement or refund for a major failure and for compensation for any other reasonably foreseeable loss or damage. You are also entitled to have the goods repaired or replaced if the goods fail to be of acceptable quality and the failure does not amount to a major failure.

Should your Davey product require repair or service after the guarantee period; contact your nearest Davey Dealer or phone the Davey Customer Service Centre on the number listed below.

For a complete list of Davey Dealers visit our website (davey.com.au) or call:



Davey Water Products Pty Ltd
Member of the GUD Group
ABN 18 066 327 517

AUSTRALIA

Customer Service Centre
6 Lakeview Drive,
Scoresby, Australia 3179
Ph: 1300 232 839
Fax: 1300 369 119
Email: sales@davey.com.au
Website: davey.com.au

NEW ZEALAND

Customer Service Centre
7 Rockridge Avenue,
Penrose, Auckland 1061
Ph: 0800 654 333
Fax: 0800 654 334
Email: sales@dwp.co.nz
Website: daveynz.co.nz

© Davey is a registered trademark of Davey Water Products Pty Ltd. © Davey Water Products Pty Ltd 2017.

P/N 48661-10

* Installation and operating instructions are included with the product when purchased new. They may also be found on our website.